

Clutch System

GENERAL

SPECIFICATIONS	CH - 2
TROUBLESHOOTING	CH - 3
SPECIAL TOOLS	CH - 5

CLUTCH SYSTEM

CLUTCH COVER AND DISC

COMPONENTS	CH - 6
INSPECTION	CH - 7
REPLACEMENT	CH - 7

CLUTCH MASTER CYLINDER

COMPONENTS	CH -10
REMOVAL	CH -11
INSPECTION	CH -13

CLUTCH PEDAL

COMPONENTS	CH -14
INSPECTION	CH -15
REPLACEMENT	CH -15
ADJUSTMENT	CH -16

CLUTCH RELEASE CYLINDER

COMPONENTS	CH -17
REPLACEMENT	CH -18



GENERAL

SPECIFICATIONS EFCBA0B1

Clutch operation method	Hydraulic type
Clutch disc Type	Single dry with diaphragm
Clutch cover assembly Type	Diaphragm spring strap

SERVICE STANDARD

Standard value Clutch disc thickness [When free] Distance between inner pad and clutch pedal Clutch pedal free play Clutch pedal stroke	8.5 ± 0.3 mm (0.326 ~ 0.350 in.) 252 ± 2mm(9.84 ~ 10.00in.) 13 mm (0.51 in.) or less 150 mm (5.9 in.)
Limit Clutch disc rivet sink Diaphragm spring end height difference Clutch release cylinder clearance to piston Clutch master cylinder clearance to piston	0.3 mm (0.011 in.) 0.5 mm (0.02 in.) 0.15 mm (0.006 in.) 0.15 mm (0.006 in.)

TIGHTENING TORQUE

Item	Nm	kgf-cm	lbf-ft
Ignition lock switch	8 ~ 10	80 ~ 100	5.9 ~ 7.4
Clutch pedal mounting	25 ~ 35	250 ~ 350	18.4 ~ 25.8
Clutch tube to clutch oil chamber	13 ~ 17	130 ~ 170	9.6 ~ 12.5
Clutch tube to clutch master cylinder	12 ~ 16	120 ~ 160	8.9 ~ 11.8
Clutch tube to clutch gose	13 ~ 17	130 ~ 170	9.6 ~ 12.5
Clutch release cylinder to clutch hose	25 ~ 35	250 ~ 350	18.4 ~ 25.8
Clutch oil chamber mounting	6 ~ 8	60 ~ 80	4.4 ~ 5.9
Clutch release cylinder bleeder screw	12 ~ 20	120 ~ 220	8.9 ~ 14.8
Clutch cover	15 ~ 22	150 ~ 220	11.1 ~ 40.1
Clutch mounting	43 ~ 55 8 ~ 10	430 ~ 550 (3EA) 80 ~ 100 (2EA)	5.9 ~ 7.4

LUBRICANTS

Items	Specified lubricants	Quantity
Contact surface of release bearing and fulcrum of clutch release fork	CASMOLY L 9508	As required
Inner surface of clutch release bearing	CASMOLY L 9508	As required
Inner surface of clutch release cylinder and outer circumference of piston and cup	Brake fluid DOT 3 or DOT 4	As required
Inner surface of clutch disc spline	CASMOLY L 9508	0.29 g
Inner surface of clutch master cylinder and outer circumference of piston assembly	Brake fluid DOT 3 or DOT 4	As required
Clutch master cylinder push rod, clevis pin and washer	Wheel bearing grease SAE J310, NLGI No.2	As required
Clutch pedal shaft and bushings	Chassis grease SAE J310a, NLGI No.1	As required
Contact portion of release fork to release cylinder push rod	CASMOLY L 9508	As required
Input shaft spline	CASMOLY L 9508	As required

TROUBLESHOOTING

ED0C552C

Trouble symptom	Suspect area	Remedy (See page)
Clutch slipping <ul style="list-style-type: none"> • Car will not respond to engine speed during acceleration • Insufficient vehicle speed • Lack of power during uphill driving 	Insufficient pedal free play	Adjust
	Clogged hydraulic system	Correct or replace parts
	Excessive wear of clutch disc facing	Replace
	Hardened clutch disc facing, or oil on surface	Replace
	Damaged pressure plate or flywheel	Replace
	Weak or broken pressure spring	Replace
Difficult gear shifting (gear noise during shifting)	Excessive pedal free play	Adjust
	Hydraulic system fluid leaks, air trapping or clogging	Repair or replace parts
	Unusual wear or corrosion of the clutch disc spline	Replace
	Excessive vibration (distortion) of the clutch disc	Replace

Trouble symptom		Suspect area	Remedy (See page)
Clutch noisy	When the clutch is not used	Insufficient play of the clutch pedal	Adjust
		Excessive wear of the clutch disc facing	Replace
	A noise is heard after the clutch is disengaged	Unusual wear and/ or damage of the release bearing	Replace
	A noise is heard when the clutch is disengaged	Insufficient grease on the sliding surface of the bearing sleeve	Repair
		Improperly installed the clutch assembly or bearing	Repair
A noise is heard when the car suddenly rolled up with the clutch partially engaged	Damaged pilot bushing	Replace	
Hard pedal effort		Insufficient lubrication of the clutch pedal	Repair
		Insufficient lubrication of the spline part of clutch disc	Repair
		Insufficient lubrication of the clutch release lever shaft	Repair
		Insufficient lubrication of the front bearing retainer	Repair
Hard to shift or will not shift		Excessive clutch pedal free play	Adjust the pedal free play
		Faulty of the clutch release cylinder	Repair the release cylinder
		Clutch disc out of place, runout is excessive or lining broken	Inspect the clutch disc
		Spline on the input shaft or clutch disc dirty or burred	Repair as necessary
		Faulty of the clutch pressure plate	Replace the clutch cover
Clutch slips		Insufficient of the clutch pedal free play	Adjust the pdal free play
		Clogged of the hydraulic system	Repair or replace parts
		Clutch disc lining oily or worn out	Inspect the clutch disc
		Faulty of the pressure plate	Replace the clutch cover
		Binding of the release fork	Inspect the release fork
Clutch grabs/chatters		Clutch disc lining oily or worn out	Inspect the clutch disc
		Faulty the pressure plate	Replace the clutch cover
		Bent the clutch diaphragm spring	Replace the clutch cover
		Worn or broken torsion spring	Replace the clutch disc
		Loose the engine mounts	Repair as necessary
Clutch noisy		Damaged the clutch pedal bushing	Replace the clutch pedal bushing
		Loose part inside housing	Repair as necessary
		Worn or dirty release bearing	Replace the replease bearing
		Sticking release fork or linkage	Repair as necessary

SPECIAL TOOLS E28FBE25

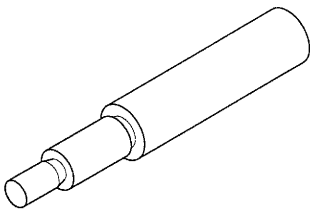
Tool (Number and name)	Illustraion	Use
09411-11000 Clutch disc guide	 EOKD001A	Installation of the clutch disc.

CLUTCH SYSTEM

CLUTCH COVER AND DISC

COMPONENTS EA2C1CB8

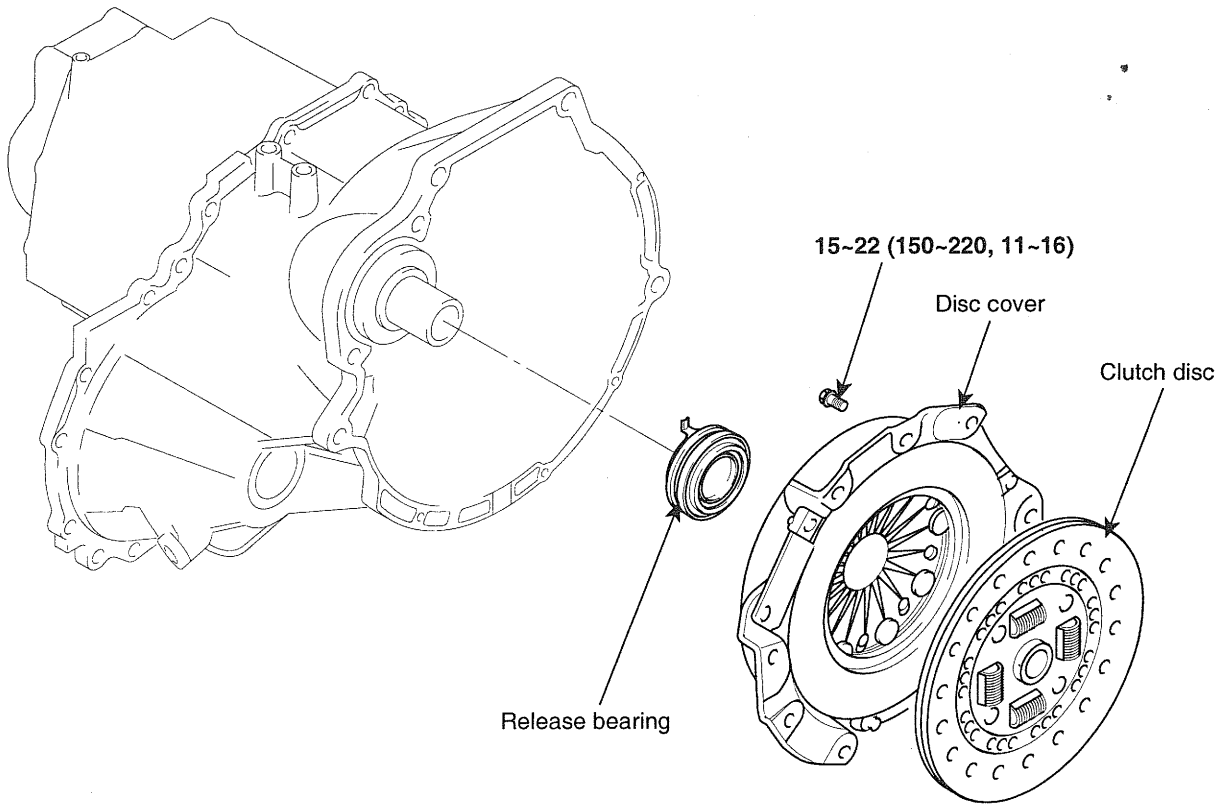

TORQUE: Nm (kg•cm, lb•ft)

INSPECTION E4FDE745

CLUTCH COVER ASSEMBLY

1. Check the diaphragm spring end for wear and uneven height.
2. Check the pressure plate surface for wear, cracks and color change.
3. Check the rivets for looseness and replace the clutch cover assembly if necessary.

CLUTCH DISC

1. Check the clutch facing for loose rivets, uneven contact, deterioration due to seizure, adhesion of oil, or grease, and replace the clutch disc if defective.
2. Measure the thickness of the disc when free.

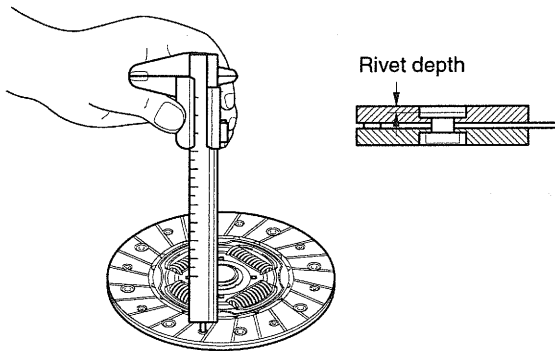

EOKD010A

3. Check for the torsion spring play and damage and if defective, replace the clutch disc.
4. Clean the splines on the input shaft and install the clutch disc.
If the disc does not slide smoothly or if play is excessive, replace the clutch disc and/or the input shaft.

CLUTCH RELEASE BEARING

 CAUTION

The release bearing is packed with grease. Do not use cleaning solvent or oil.

1. Check the bearing for seizure, damage or abnormal noise. Also check the diaphragm spring contacting points for wear.
2. Replace the bearing if the release fork contacting points are worn abnormally.

CLUTCH RELEASE FORK

If there is abnormal wear at the point of contact with the bearing, replace the release fork assembly.

REPLACEMENT EE1170CF

1. To Remove the transaxle assembly. (See 'TR' group - 'Manual Transaxle')
2. If the clutch cover is attached to the flywheel, remove the release bearing using snap-ring pliers.
 - 1) Rotate the release bearing in an easy direction in order to examine the snap ring.
 - 2) Insert the pliers under the wave washer as shown in the illustration and place it in the center of the snap ring.
 - 3) Spread the snap ring by pushing down on the bearing as shown in the illustration.

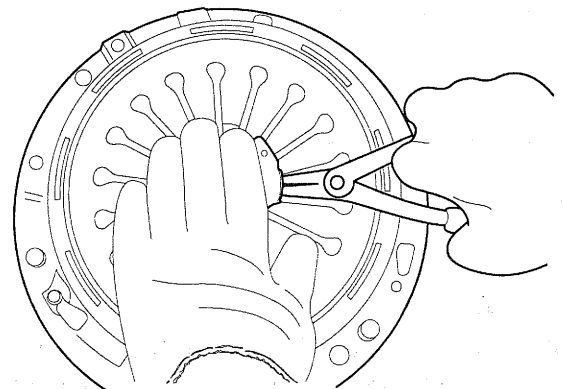

EOKD008A

- 4) The snap ring (A) at expanded state is shown in the figure.

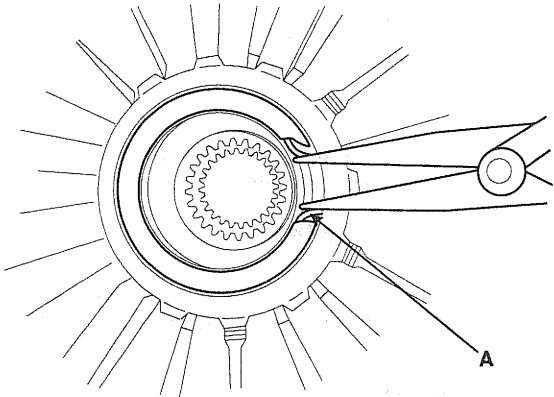

EOKD009A

- 5) In the snap ring expanded, pull out the release bearing and remove it.
3. Insert the special tool (09411-11000) in the clutch disc to prevent the disc from shifting.
4. Loosen the bolts which attach the clutch cover to the flywheel in a star pattern. Loosen the bolts in succession, one or two turns at a time, to avoid bending the cover.

NOTE

Do not clean the clutch disc or the release bearing with cleaning solvent.

5. Remove the release fork shaft and bushing.
6. Apply multipurpose grease to the spline of the disc.

Grease: CASMOLY L 9508 0.2gr

CAUTION

When installing the clutch, apply grease to each part, but be careful not to apply excessive grease. It can cause clutch slippage and judder.

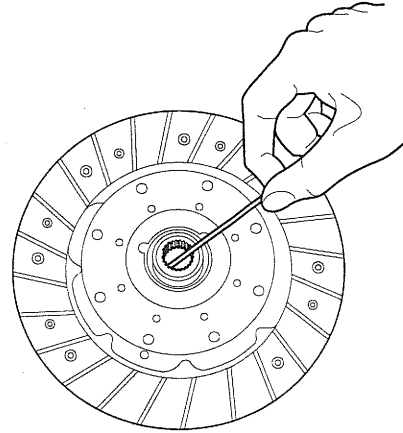

EOKD011A

7. Install the clutch disc assembly to the flywheel using the special tool (09411-11000).
8. Install the clutch cover assembly to the flywheel and temporarily tighten the bolts one or two steps at a time in a star pattern.

Tightening torque

Clutch cover bolt:

15 ~ 22 Nm (150~220 kgf-cm, 11~16 lbf-ft)

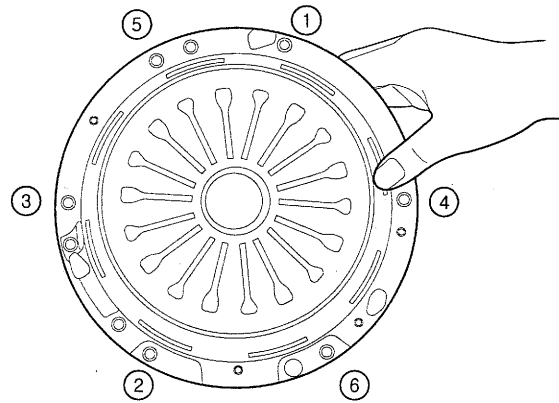

EOKD012A

- Align the bearing (A) to the release fork (B) and then install it to the sleeve of the housing.

⚠ CAUTION

Apply multipurpose grease (CASMOly L9508) to the bearing sleeve and contact point of the release fork.

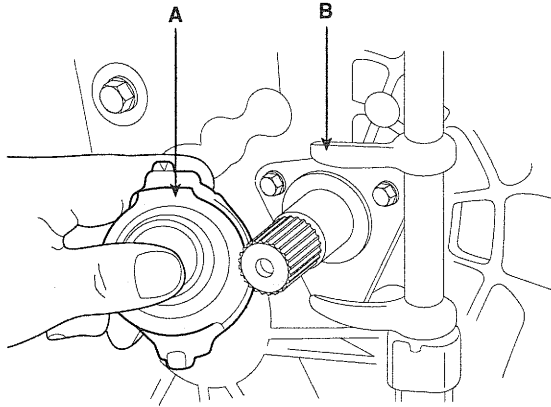

EOKD013A

- Install the release lever to the release fork.

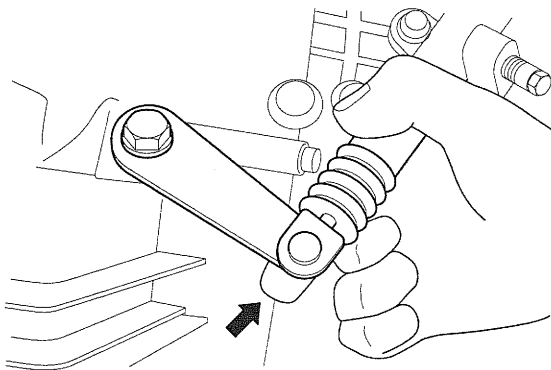

EOKD014A

- Install the transaxle assembly to the engine.

⚠ CAUTION

If the transaxle assembly is installed to the engine without performing this step, the release bearing can be separated, as the release fork rotates freely.

- After finishing step 6, push the release lever to the arrow mark. If there is a click sound, the release bearing and clutch cover are aligned correctly. If the assembly does not snap into place, start with step 1 again. Release lever operating range is 3° or less. If the range is over 3°, the release bearing and clutch cover are not aligned correctly. Push the release lever to the arrow mark one more time.

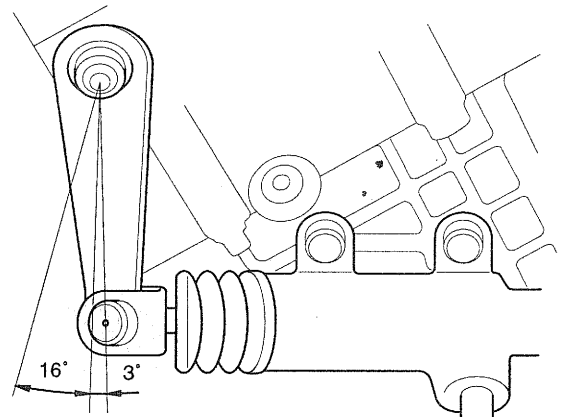

EOKD015A

CLUTCH MASTER CYLINDER

COMPONENTS E8BF9DD4

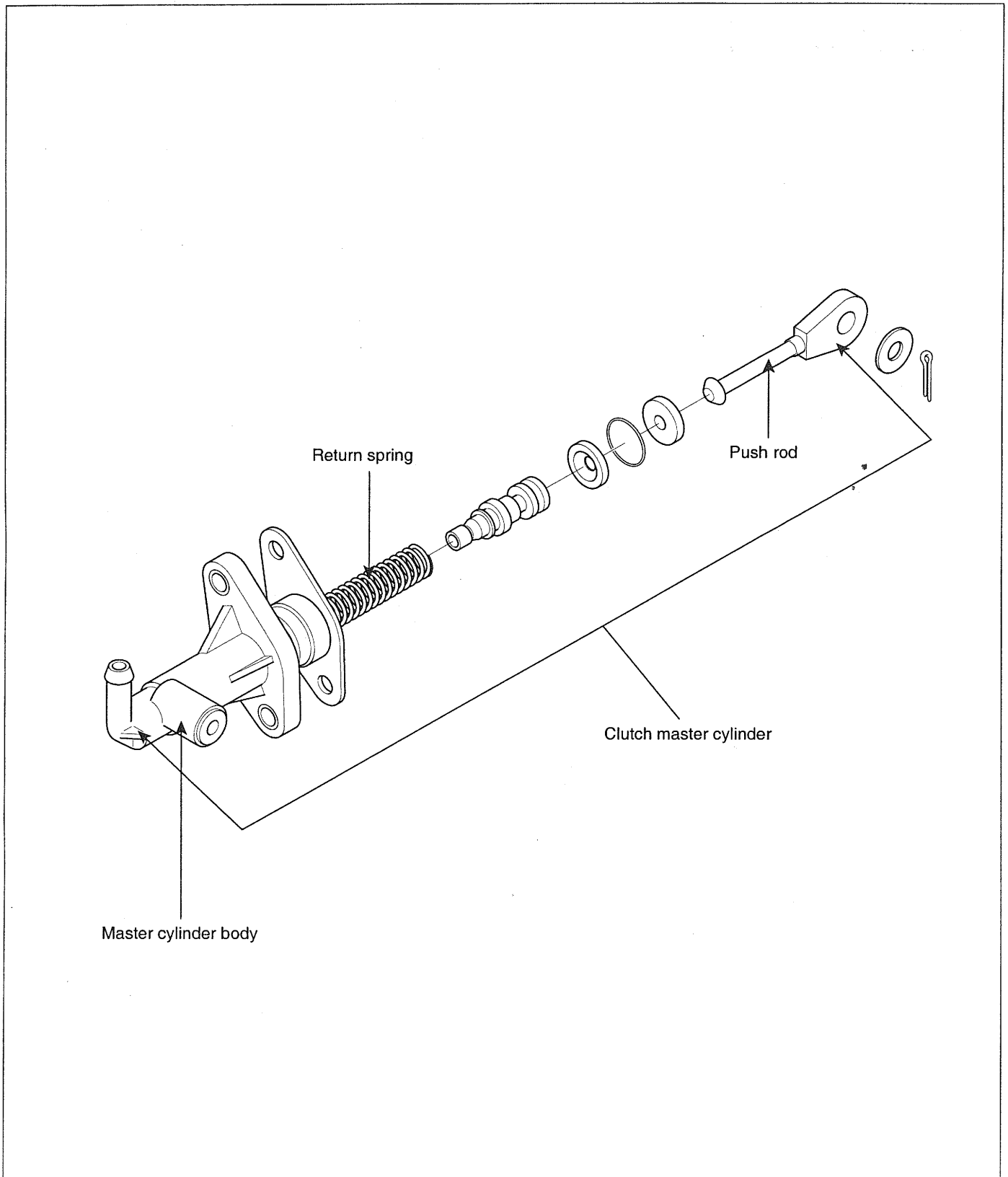

REMOVAL E3BFDB69

1. Drain the clutch fluid through the bleed plug (A).

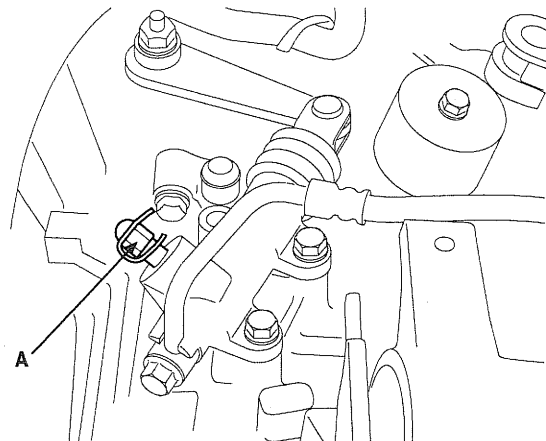

EOKD101A

2. Remove clevis pin (A), split pin (cotter pin) (C) and washer (B).

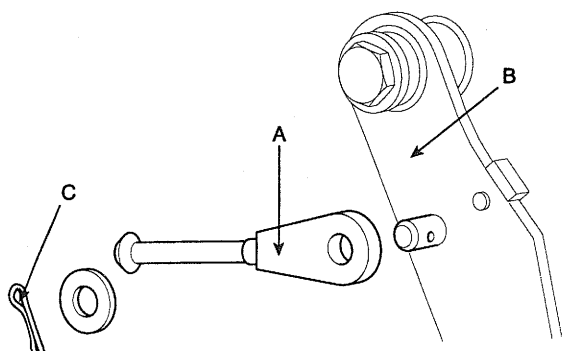

EOKD045C

3. Disconnect the clutch tube (A) (master cylinder side).

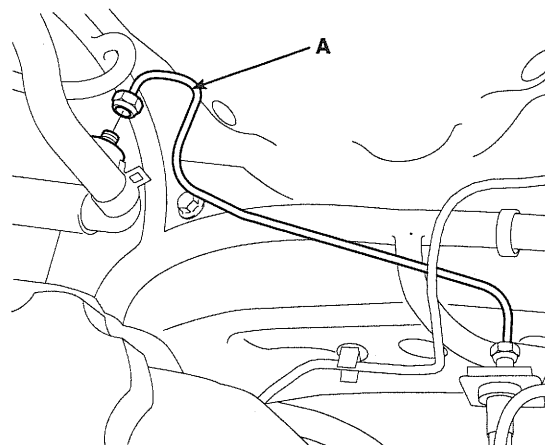

EOKD102A

4. Remove the master cylinder mounting nuts.
5. Remove the clutch line clips (A).
6. Hold the nut on the clutch hose (B) and loosen the flare nut (C) on the clutch tube.

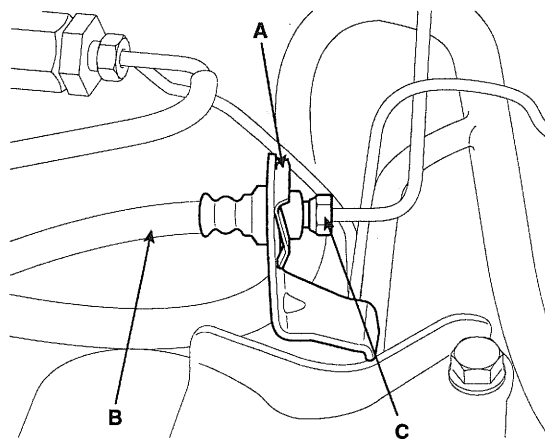

EOKD104A

7. Remove the clutch tube.

8. Disconnect the clutch hose (A) (release cylinder side).

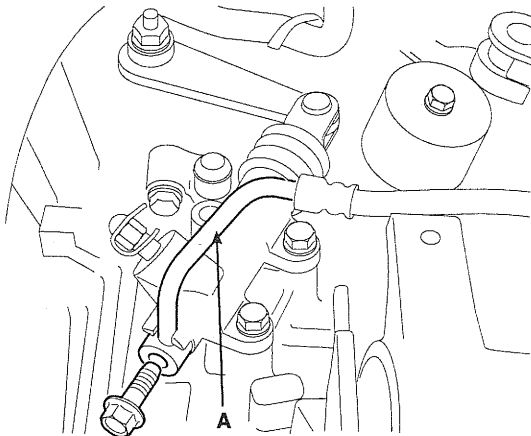

EOKD105A

10. Temporarily tighten the flare nut by hand, then tighten it to the specified torque, being careful that the clutch hose does not become twisted.

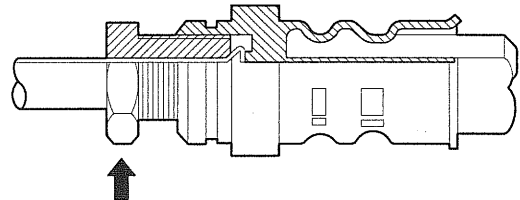

9. Connect the clutch tube (A) (release cylinder side).

EOKD017A

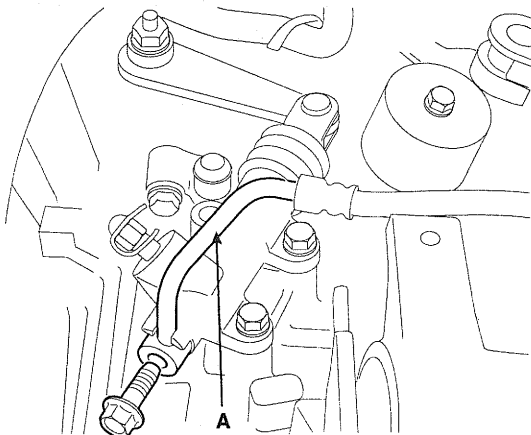

EOKD105A

11. Install the clutch tube and clips (A).

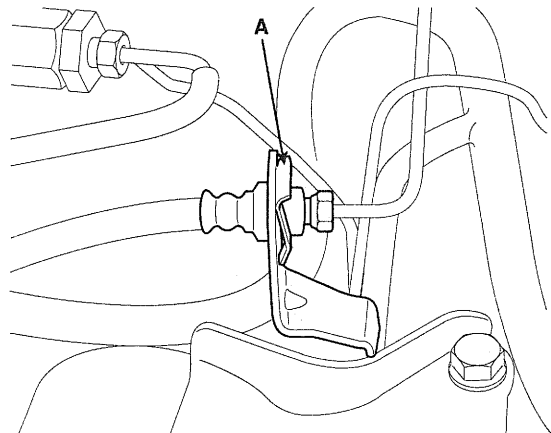

EOKD104B

12. Install the master cylinder.

13. Apply the specified grease to the clevis pin and washer.

Wheel bearing grease: SAE J310a, NLGI NO. 2

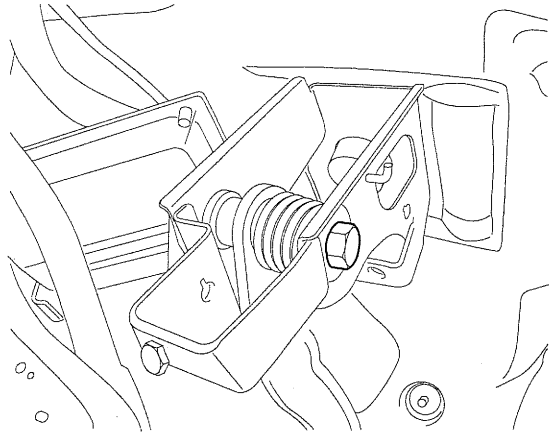

EOKD018A

14. Install the push rod to the clutch pedal.
15. Pour the clutch fluid into the clutch master cylinder.
16. Bleed the clutch system.

INSPECTION E9B62A6F

1. Check the inside of the cylinder body for rust, pitting or scoring.
2. Check the piston cup for wear or distortion.
3. Check the piston for rust, pitting or scoring.
4. Check the clutch tube line for clogged.
5. Measure the master cylinder inside diameter and the piston outside diameter with a cylinder gauge micrometer.

NOTE

Measure the inside diameter of the master cylinder at three places (bottom, middle, and top) in a perpendicular direction.

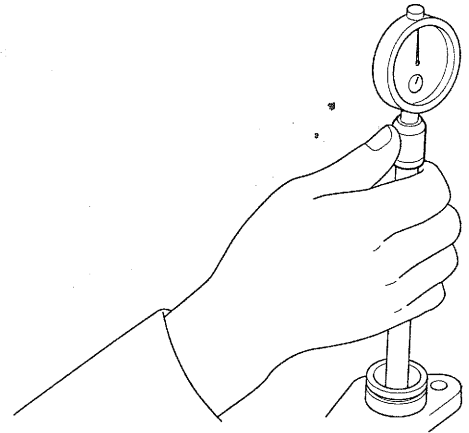

EOKD100A

6. If the master cylinder-to-piston clearance exceeds the limit, replace the master cylinder and/or piston assembly.

Limit: 0.15 mm (0.006 in.)

CLUTCH PEDAL

COMPONENTS EB733EEB

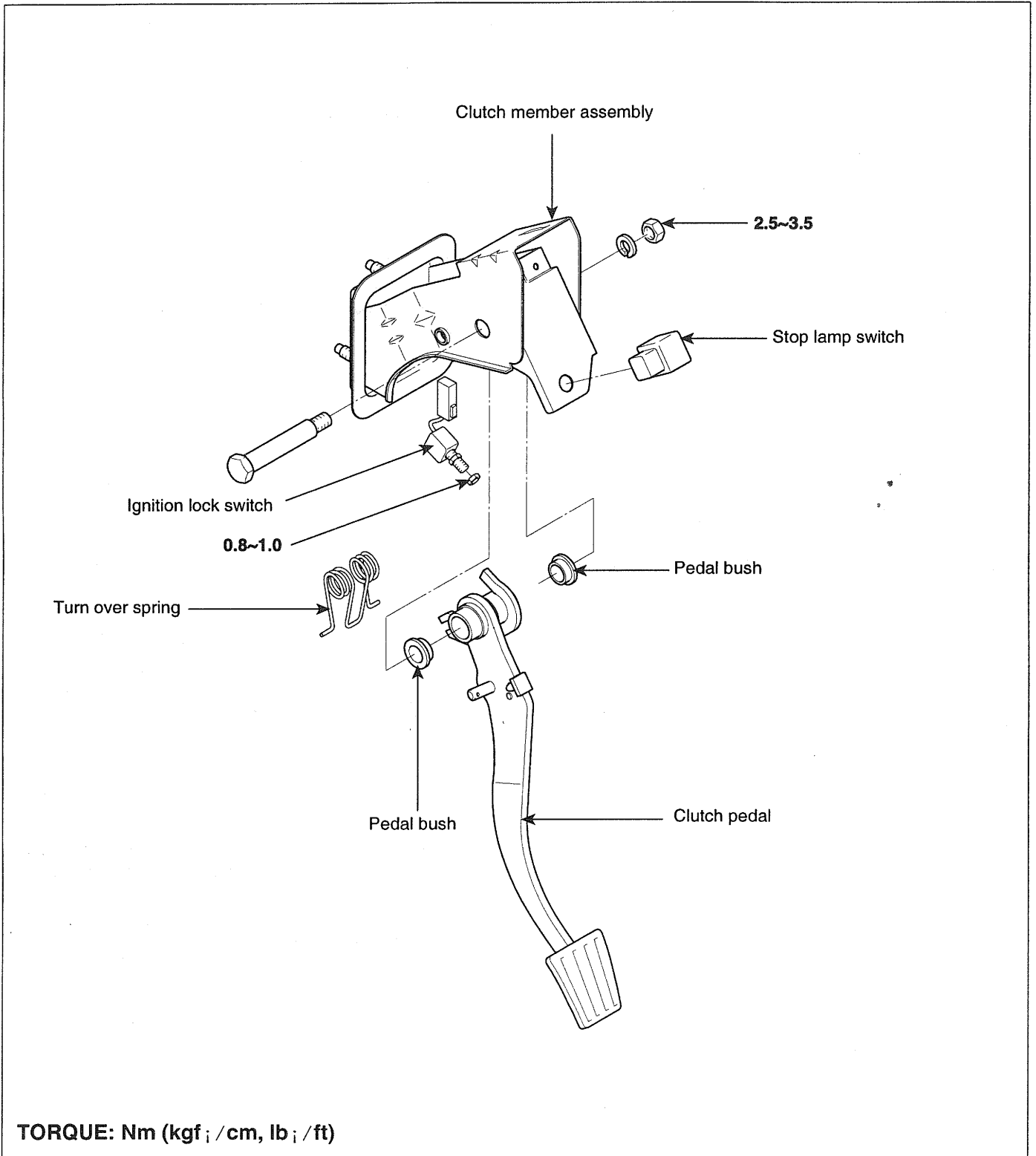

TORQUE: Nm (kgf ; /cm, lb ; /ft)

INSPECTION E8CD0009

1. Check the pedal shaft and bushing for wear.
2. Check the clutch pedal for bending or torsion.
3. Check the return spring for damage or deterioration.
4. Check the pedal pad for damage or wear.

IGNITION LOCK SWITCH INSPECTION

Remove the ignition lock switch and check for continuity between the terminals. If the continuity is not as specified, replace the switch.

Terminal	1	2
Condition		
Pushed	○ ————— ○	
Free		

EOKD021B

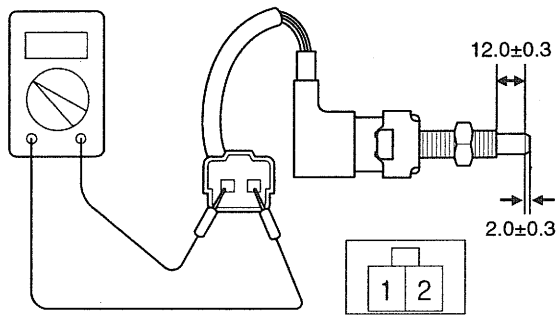

EOKD021A

RETURNING TEST OF CLUTCH PEDAL.

Deformation of pedal pad must be MAX. 5mm after repeating the test 20 times (sudden return from full stroke).

REPLACEMENT E606EDEB

1. Remove the cotter pin (A), washer (B), and clevis pin (C).

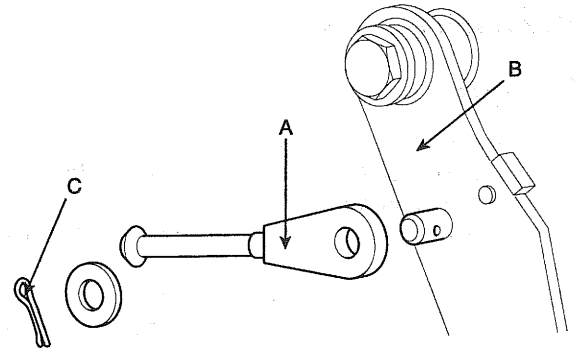

EOKD045C

2. Remove the clutch pedal mounting bolts.
3. Apply the specified grease to the clutch pedal and bushings.

Chassis grease: SAE J310a, NLGI No.1

4. Install the clutch pedal mounting bolt.

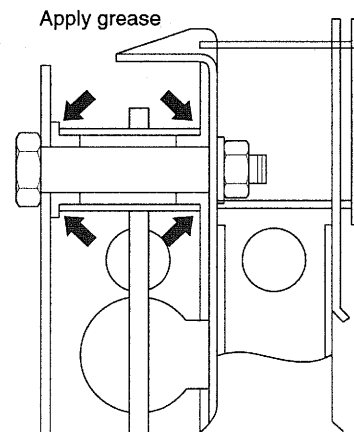

EOKD022A

5. Apply the specified grease to the clevis pin and washer.

Wheel bearing grease: SAE J310, NLGI No.2

6. Install the push rod to the clutch pedal.

ADJUSTMENT ECB3EE0A

NOTE

- Check for the ignition lock switch.
In case of clutch lock system vehicle, there is an additional switch.
- Before adjusting, remove the driver's floor seat.

1. After loosening the ignition lock switch nut, move it back until it has no contact with the clutch pedal arm. (In case of clutch lock system vehicle, repeat this step with its additional ignition lock switch).
2. Check for the specification below.

Clutch pedal stroke : 150 mm
Clutch pedal free play : 13 mm or less
Distance between the inner pad and clutch pedal : 250 ~ 254 mm

3. Fix the ignition switch when its signal is OFF pressing the pedal slowly (52 ~ 58 mm).
Tighten the fixing nut with specification

TORQUE : 8~ 10 Nm (80 ~ 100 kgf-cm, 5.9 ~ 7.4 lbf-ft)

4. (Clutch lock system vehicle)
Fix the additional ignition lock switch when its signal is ON pressing the pedal slowly (117 ~ 123 mm).
Tighten the fixing nut with specification.

CLUTCH RELEASE CYLINDER

COMPONENTS E10E6DB6

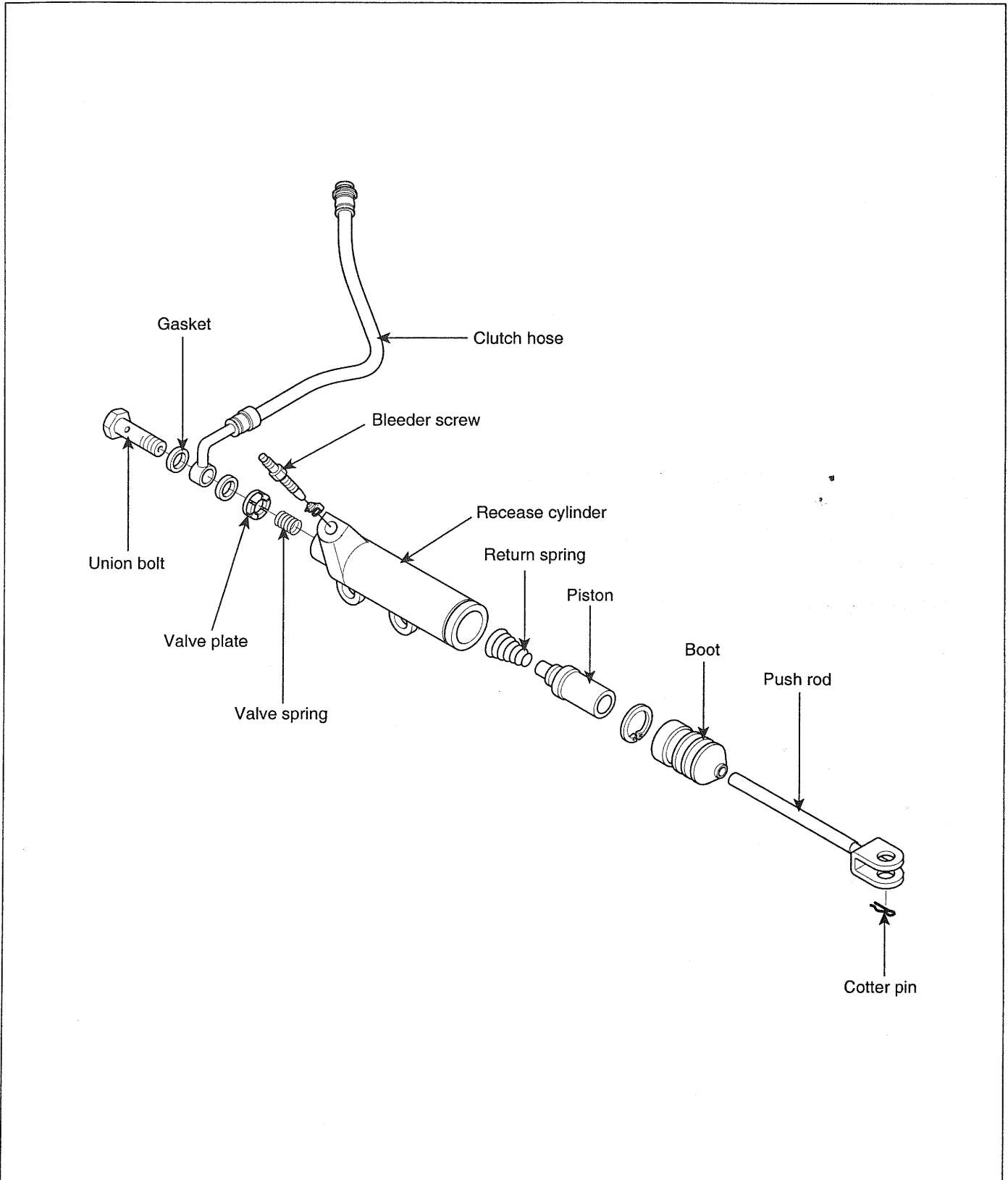

REPLACEMENT ED3AF2B5

1. Drain the fluid from the bledding ply(A).

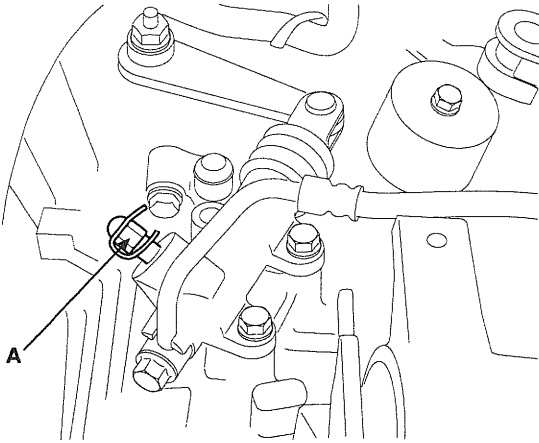

EOKD101A

2. Clamp the clutch hose between the clutch release cylinder and the clutch tube.
3. Remove the clutch release cylinder loosening the mounting bolt.
4. Install the new clutch release cylinder.